

4/5/6/7/8/9/10 鋁製容器の陽極酸化処理手順

陽極酸化処理の準備

- 鋁製容器を洗剤で洗浄し、水でよくすすぎ、乾燥させる。
- 陽極酸化槽に電解液（硫酸希釈液）を注入し、温度を 280 °C に設定する。
- 鋁製容器を電解液中に浸漬し、電圧を 12V に設定する。
- 陽極酸化処理が完了したら、電圧を 0V に設定し、容器を取り出す。

陽極酸化処理の注意事項

1. 鋁製容器の材質を確認する。---
2. 電解液の濃度を調整する。---
3. 電圧を適切に設定する。---
4. 陽極酸化処理の時間、電圧を 9-11V に設定する。
5. 陽極酸化処理の温度を 280 °C に設定する。
6. 陽極酸化処理が完了したら、電圧を 0V に設定し、容器を取り出す。





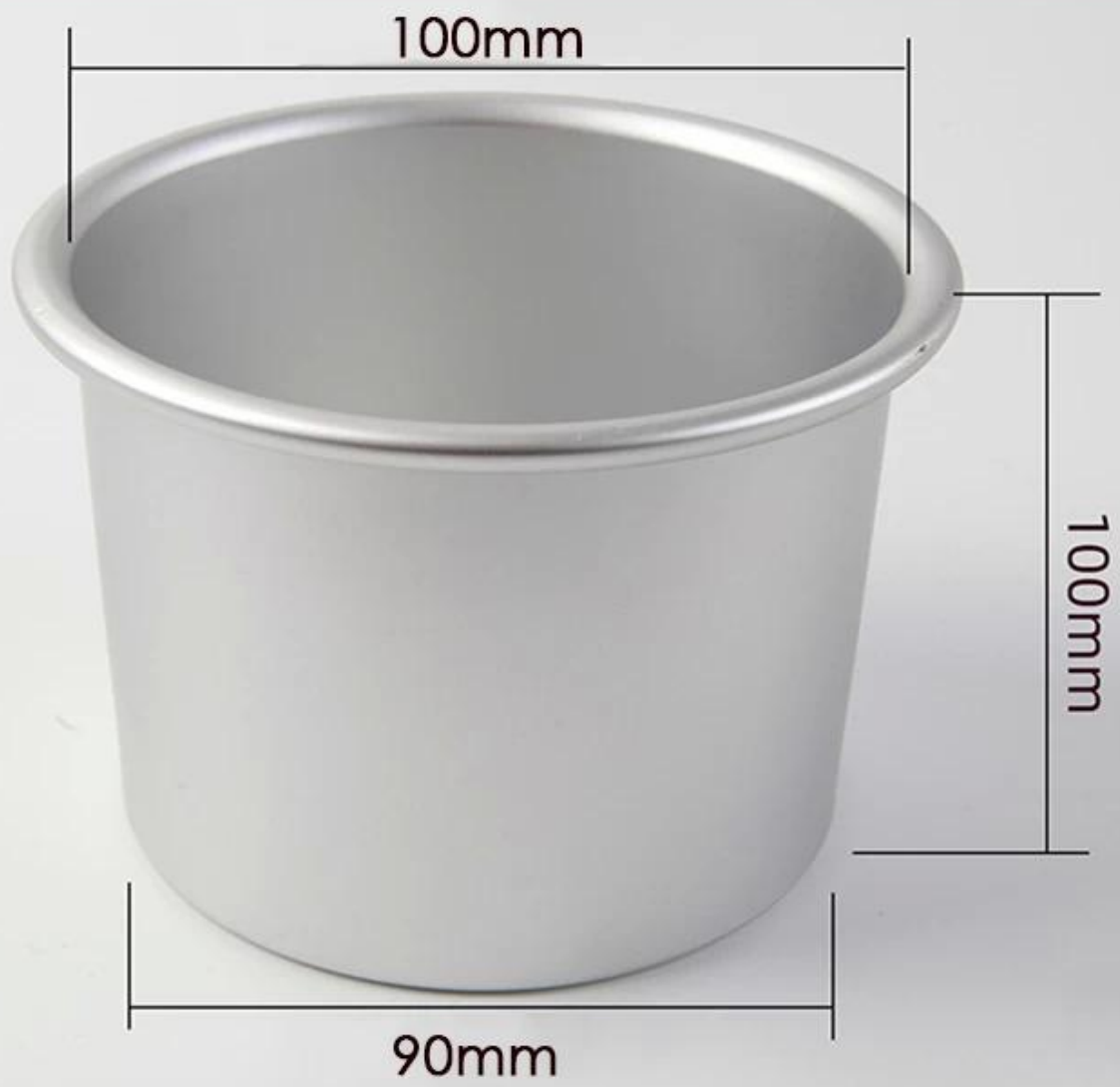

4" Deep Cake Pan
weight: 68g

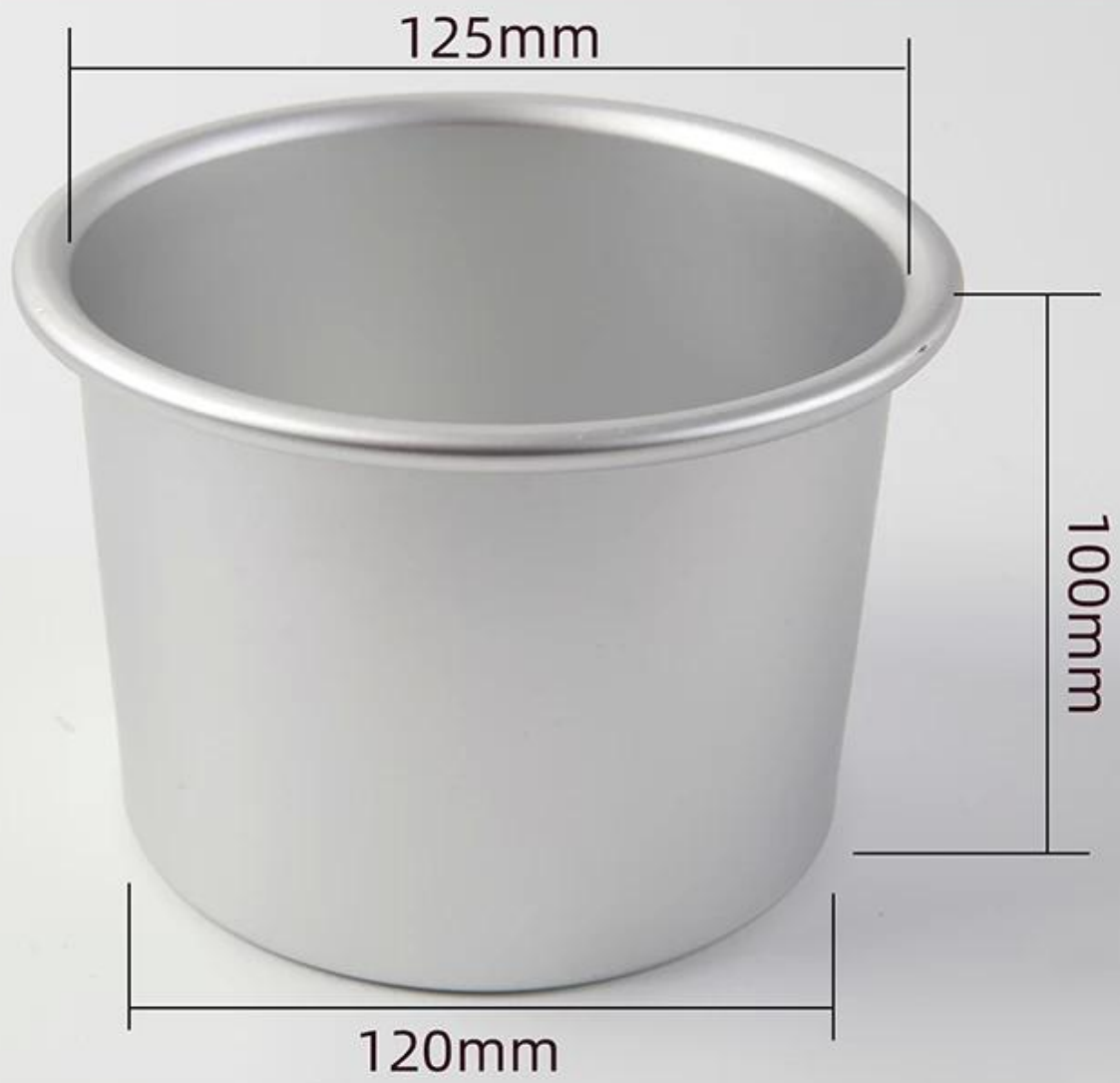

5" Deep Cake Pan
weight: 88g

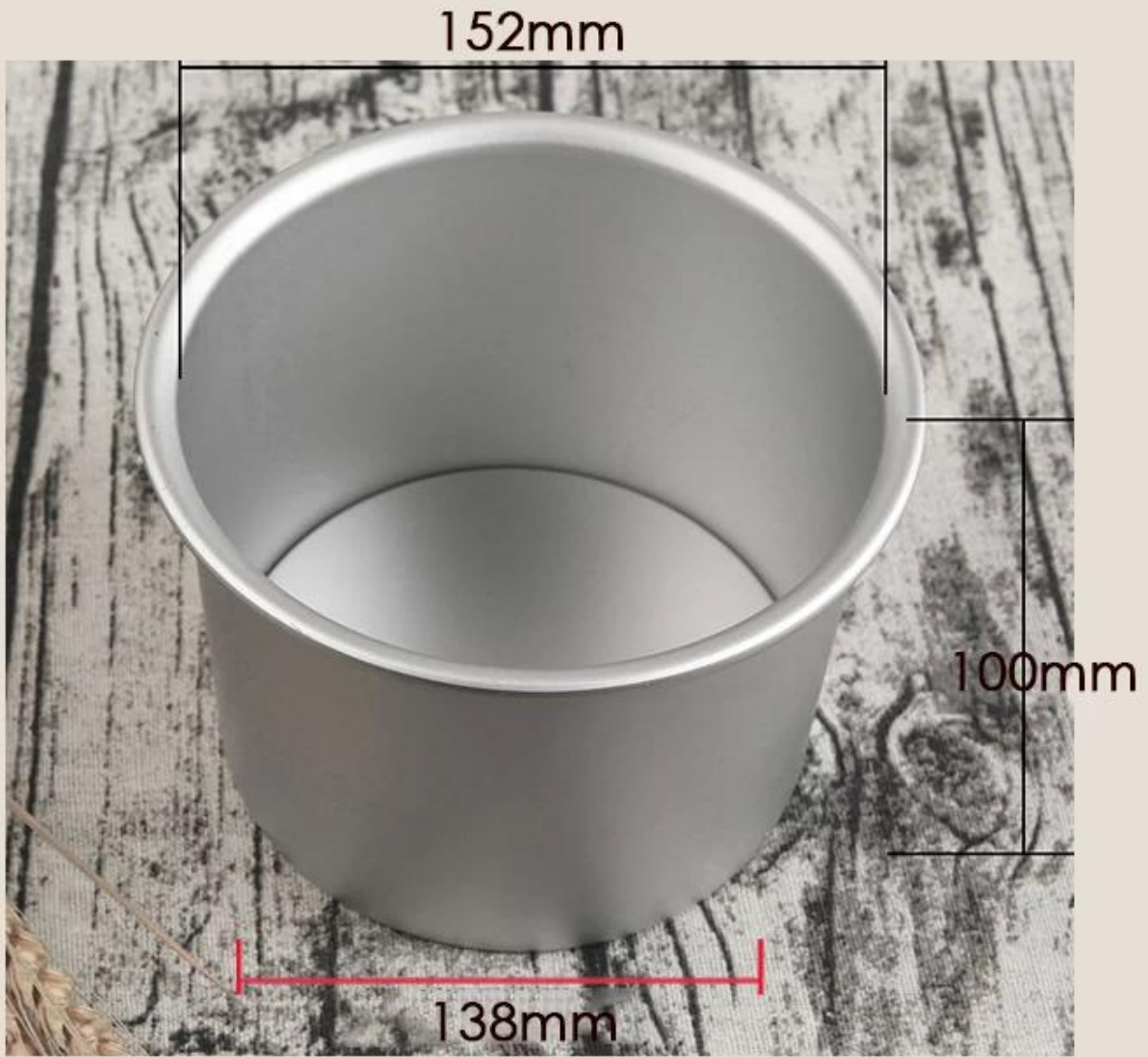

6" Deep Cake Pan
weight: 180g



7" Deep Cake Pan
weight: 230g



8" Deep Cake Pan
weight: 290g



9" Deep Cake Pan
weight: 330g



10" Deep Cake Pan
weight: 370g





 Zoe Lee	TSINGBUY INDUSTRY LIMITED FACTORY PLANET OEM & ODM - Bakeware and Customization	
 Tel	+86 186 1186 6087	+86 0755-85234769
 Email	marketing@tsingbuy.com	
 Skype	+86 186 1186 6087	
 Whatsapp	+86 186 1186 6087	
 Web	www.chinabakeware.com	
 ADD	2 Floor B1 Building, No 22 Dafu Industry park, Guanlan, Longhua District, Shenzhen, China 518110	