

# Anodized Aluminum Bundt Cake Pan Ring Shape Baking Mold with Detachable Hollow in Center Cakes Baking Tin

## **Main features of Anodized Aluminum Bundt Cake Pan Ring Shape Baking Mold with Detachable Hollow in Center Cakes Baking Tin**

- 1.0 thickened high quality aluminum alloy material, light material, fast heat conduction;
- High density, high temperature resistance, high hardness, firmness and no deformation,
- Anode treatment and smooth surface are more conducive to cake climbing;
- Heightening design, clean and sanitary, long service life;

## **Bundt cake pan images**



Custom Design Chart  
— Tsingbuy bakeware manufacturer

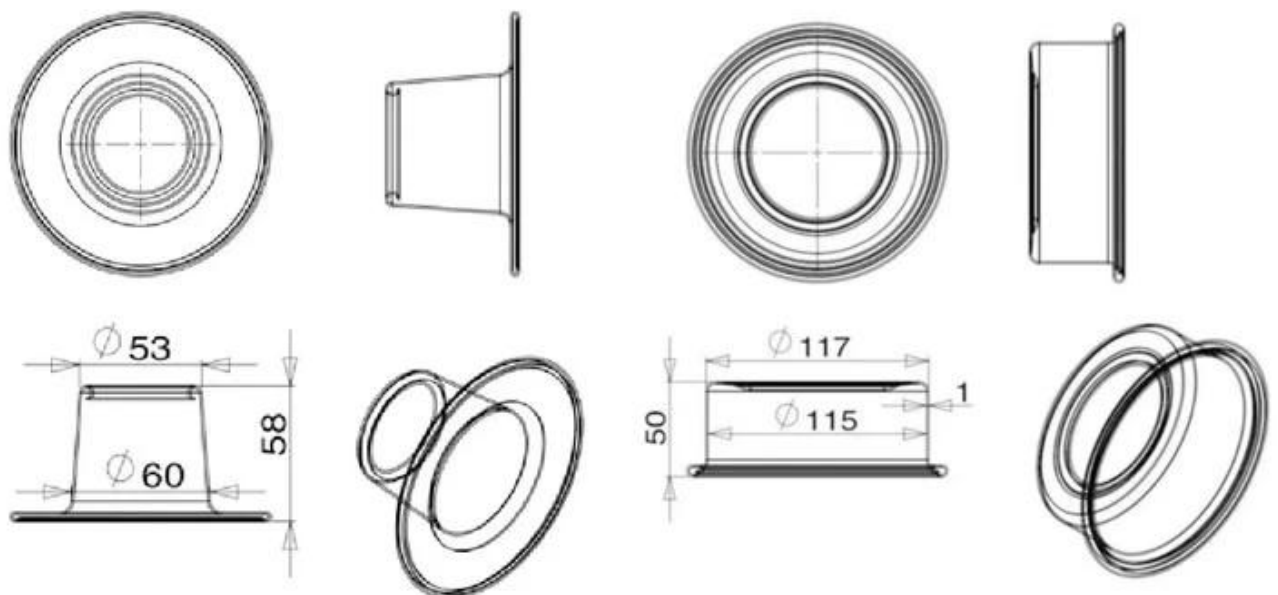









**Bundt cake pan in application**







Click here to view factory videos: [baking pan manufacturer](#)

More [bundt cake pan wholesale](#) in multiple sizes.

